

STAMPA ROTATIVA 800 MM
 ROTATIVE PRINTING 800 MM

STAMPA QUADRO
 AREA MAX 650X810 MM
 FLAT SCREEN PRINTING
 MAX 650X810 MM

CAPPA IR 50 - 6 KW
 FLASH CURE UNIT
 IR50 - 6KW

STAMPA QUADRO
 AREA MAX 1100X810 MM
 FLAT SCREEN PRINTING
 MAX 1100X810 MM

ROTOSCREEN
 800 MM

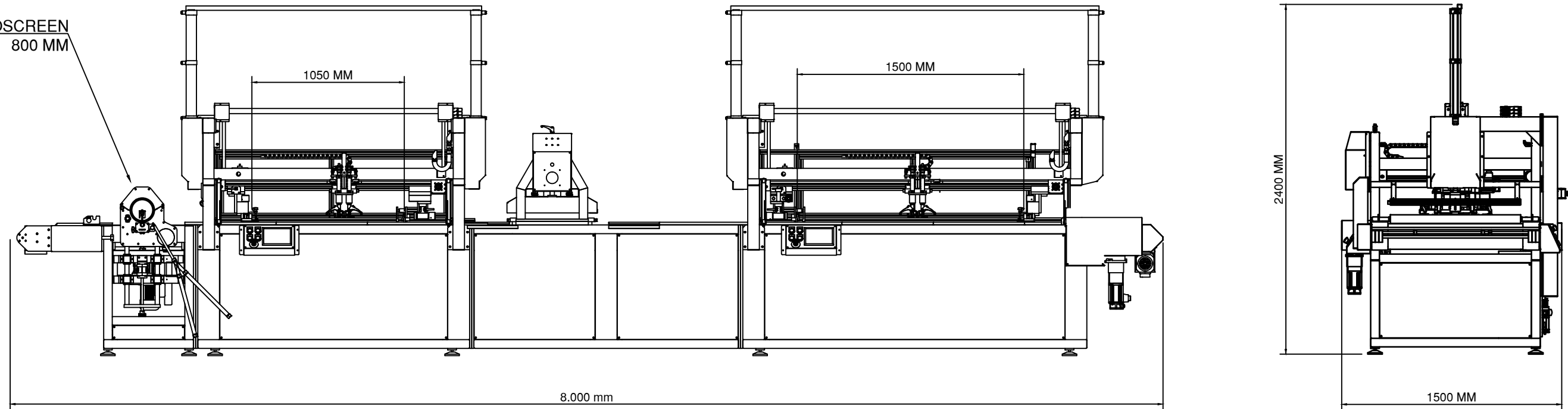

GA-2 FORMATO STAMPA 1° 800X650 MM + 2° 800X1100 MM + ASCIUGATURA CON CAPPA IR 500 MM + ROTOSCREEN 800 MM
 GA-2 PRINTING SIZE 1° 800X650 MM + 2° 800X1100 MM + FLASH CURE DRYER IR 500 MM + ROTOSCREEN 800 MM